

Developing step-change technology

Flowline Systems:
enabling optimal field
architecture

**From concept to
commercialisation:**
market-ready Electrically
Heat Traced Flowline

Wintershall Maria:
new thinking in a
mature area

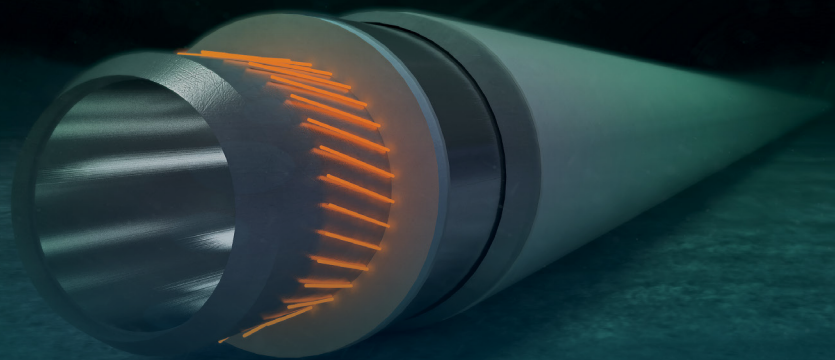

Welcome to deep7 2016

We have become accustomed to solving complex problems and continuously extending what is technically possible. The current situation, however, requires that we think and behave in different ways in order to successfully address the challenges we face.

In this issue of Deep 7, we show how our thought processes are focused on creating genuine step-changes through accelerating the development and adoption of value-adding, innovative technologies.

We also demonstrate how early engagement and true collaboration with clients and development partners can further add to the value that can be realised.

Editorial Team:
Thomas Sunde | Vice President Technology
Gordon Drummond | Technology Manager, R&D
Jan Roger Moksnes | Technology Communications
Date of print: May 2016

CONTENTS

Creating value through innovation and technology
page 3

Road-mapping our technology development
page 4

Flowline Systems:
Enabling optimal field architecture
page 6

From concept to commercialisation:
Market-ready Electrically Heat Traced Flowline
page 8

Pipeline Bundles: The next generation
page 10

Subsea processing in Towed Production Systems
page 12

Engaging early to deliver value:
The Granherne-Subsea 7 Alliance
page 14

OneSubsea Alliance:
Focus on technology
page 15

Wintershall Maria:
New thinking in a mature area
page 16

Pipeline Production Team (PPT):
Leading-edge welding technology
page 18

Deepwater Riser Systems:
A strong portfolio under continuous development
page 20

Composites: From concept to application
page 22

Data as the cornerstone of Life of Field Technology Strategy
page 23

Creating value through innovation and technology

By **Thomas Sunde** | Vice President Technology

In Subsea 7, innovation is the process of delivering value by new or improved capabilities, products, services and processes.

Based on our high level of experience, expertise and industry knowhow, we solve complex problems and unlock value for our clients. Merging industry best practices, increased collaboration and benchmarked development models has enabled us to tackle technology-rich and complex projects delivering market-driven cost-effective solutions.

We develop and apply technologies that reduce cost, enhance production and extend field life.

Development of subsea fields

Subsea technology is advancing to meet the requirements of increasingly demanding production environments: deep water, greater tie-back distances and higher reservoir temperatures and pressures.

Managing lower prices and revenues in a way that does not jeopardise future performance is the most immediate challenge but it is not the only one. The industry also has to contend with an aging and complex range of production facilities, which brings a wider range of technical, logistical and operational challenges.

This means that the industry has to find ways to reduce CAPEX costs related to subsea field developments, enable increased recovery rates, increase value extracted from existing field infrastructure, enable development of complex reservoirs and lower OPEX costs of subsea operations.

Greater productivity and efficiency can be achieved through innovation, in which Subsea 7 has a rich history. Advances in technology have led to unlocking reserves previously thought to be beyond reach. Breakthroughs in technology have also allowed us to pursue more challenging reserves. Technological innovation can change operating conditions and costs, as well as opening up new operating environments.

Our technology investment is focused on developing key technology differentiators that meet our clients' current and future challenges. Building on an extensive portfolio of solutions and existing technologies, we have mobilised a strong team to lead the development of new technologies within key areas. Our strategic technology programmes are all about creating value for our clients and our shareholders.

Step-change technologies

Subsea 7 has a market-leading portfolio of riser systems, representing the widest range of solutions in the industry and allowing fit-for-purpose selection for each project.

Our high-performance and cost-efficient flowline systems enable optimal field architecture. We are enhancing our Pipeline Bundle technology solutions and developing Towed Production Systems for the global market.



”

The result is more cost-efficient, faster and smarter solutions.

We integrate compact Subsea Processing Systems, moving topside processing facilities either in part or in their entirety to the seabed to reduce the cost and complexity of developing offshore fields. We develop a range of advanced inspection and maintenance technologies to support Life of Field strategies.

The key to technology development is true collaboration with our clients and suppliers.

The result is more cost-efficient, faster and smarter solutions. •

ROAD-MAPPING

our technology development

By **Neil Brown** | Technology Manager, Norway

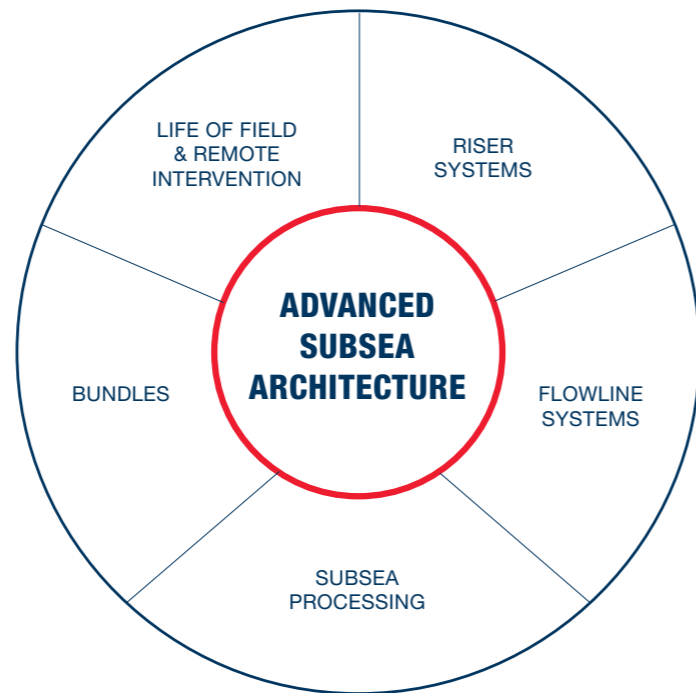

Over the last two years, our approach to technology management was mainly driven by learning from our success stories and enhancing our ability to reproduce them, gradually building on our core capabilities, values and strengths.

Our goal now is to make a step-change in our pace of innovation development to deliver the innovative solutions our clients need.

We have actively explored opportunities to collaborate with partners from other sectors of industry and academia. One significant example of this is our partnership with the Institute for Manufacturing (IfM) at the University of Cambridge to deploy strategic road-mapping techniques within our organisation.

The road-mapping technique establishes a direct link between drivers and the solutions that we need to develop. Each of these solutions is linked to a set of supporting technologies that we are able to prioritise and develop based on our strategic goals.

In practice, this means that our clients have the opportunity to directly influence our

technology agenda, since we are able to include project-specific development and qualification activities into our planning. This approach will allow us to maximise the benefits of engagement with our clients in the early phases of field development.

Our strategic technology programmes were initially created in 2014 to provide focused innovation pipelines for each of the core product groups that create value for our clients and our shareholders. These programmes now further benefit from this road-mapping approach, which provides a clearly defined set of pathways along which technology can be deployed.

Road-mapping techniques are ideally suited to a workshop format, in which stakeholders interact, discussing and evaluating creative solutions, complex ideas and business rationale. As a global organisation, however, we needed to build an effective virtual communication platform for these collaborative activities.

In 2015, we engaged with SharpCloud (a leading international developer) to deploy its visual communication software within Subsea 7. By pushing the boundaries of this software and finding new, innovative ways of working, Subsea 7 became the first organisation to successfully combine IfM's road-mapping techniques with the SharpCloud platform within virtual workshops.

This innovative way of working allows us to create a coherent narrative around our technology development activities, and keep this narrative alive within the organisation. It also helps us to develop and share our vision of our technological future in collaboration with partners and clients.

This ensures that our strategic technology programmes remain focused on real business challenges, while remaining sufficiently adaptable to meet current and future client needs. •

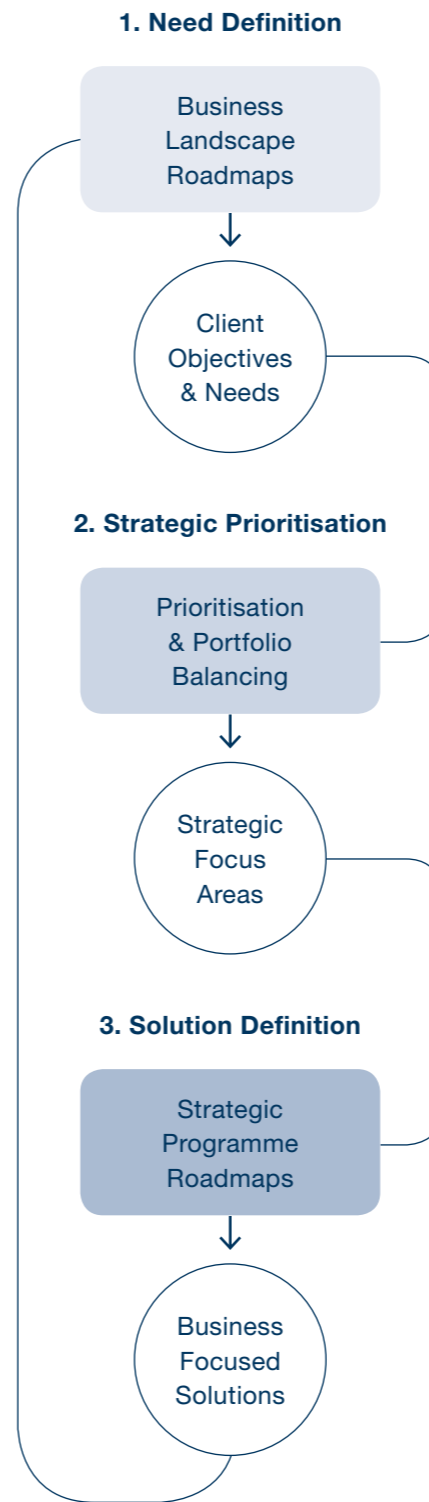

”

This innovative way of working allows us to create a coherent narrative around our technology development activities, and keep this narrative alive within the organisation.

FLOWLINE SYSTEMS: enabling optimal field architecture

By **Olivier Lodeho** | Strategic Technology Programme Manager for Flowline systems

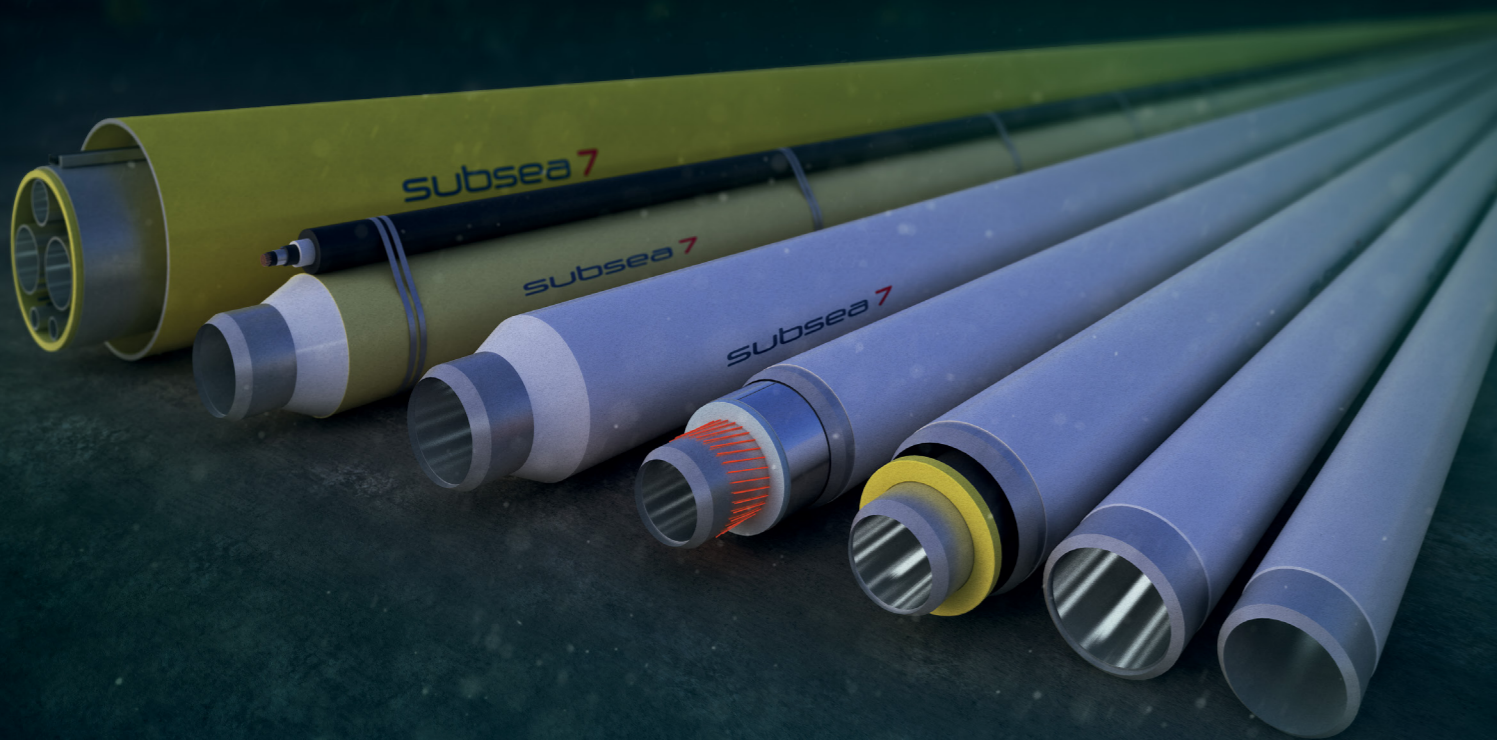

The Strategic Technology Programme for Flowline Systems covers innovation and developments on pipeline products and associated subsea structures. Our focus is on meeting client needs in terms of long tie-backs with a particular emphasis on thermal performance and corrosion resistance, from design through to installation.

Thermal performance for long tie-backs

Thicker wet-coating insulation systems are required to extend the functional applications of flowline systems, in terms of water depth, U-value and other criteria. As part of Subsea 7's ongoing development programme, in-house engineering capabilities have been strengthened, in particular to validate the field joint coating designs utilised in Reel-lay.

New in-house software tools feature the capability for rheological analysis of the field joint coating injection process and thermo-mechanical simulations of the cooling and spooling operations. This aims to ensure an optimised quality manufacturing process and that the spooling operations are within safe limits, thus avoiding cracks in coating. This development is an example of how cutting-edge technologies adopted from other industries can bring value to our business. This improves quality and reduces the tendering, development and production time, risk and ultimately cost.

For even greater step-out distances, dry insulation systems, such those used in Pipe-in-Pipe (PIP), are our focus. Subsea 7 continues to develop cost-effective solutions and technological leadership by optimising design and installation methods as demonstrated during recent projects like TEN in S-lay for Tullow, or Dalmatian in Reel-lay for Murphy.

When thermal requirements are very onerous, passive insulation systems may not be efficient enough. This can be the case with extremely long tie-backs which may require active heating solutions to maintain the temperature above wax appearance or because of cool-down scenarios.

From a cost-efficiency perspective, such an approach can reduce CAPEX by eliminating the need for looped flowlines (or a service line) for dead oil circulation. OPEX can equally be reduced through lowering the amount of chemicals injected in the flowlines, resulting in reduced time required to restart operations after

shutdown as well as limiting topsides chemical storage requirements.

Subsea 7 is a market leader in the provision of active heating solutions through our expertise and ongoing developments in the main active heating technologies:

- Direct Electrical Heating (DEH) technology; We have one of the most extensive track records in the industry (Skuld, Skarv, Morvin, Tyrihans), including the recent Lianzi Project (43kms, 1070m WD) for Chevron, the deepest DEH system implemented to date.

- Hot water heating technology, developed and integrated in Pipeline Bundle solutions, has already been implemented on the Statoil Åsgard, Statoil Gullfaks and ExxonMobil Skene Projects.

Subsea 7 has also developed the Electrically Heat Traced Flowline (EHTF), an innovative solution in partnership with manufacturer ITP. The benefit of this technology is to provide the world's leading flowline insulation performance, which in turn drastically reduces the electrical power required for heating and the associated topside equipment. Already certified by DNV for 6"x10" Pipe-in-Pipe (PIP) for Reel-lay installation, EHTF is currently under final qualification for other pipe diameters.

Corrosion resistance

Among the flowline challenges that our clients need to overcome are corrosion issues. Subsea 7 is continuously developing alternative cost-effective solutions like BuBi® pipe with manufacturer Butting, which has been qualified with Fatigue Class C testing for dynamic riser applications on Sapinhoá-Lula for Petrobras, and for HP/HT flowline application with lateral buckling on the Maria Project for Wintershall in 2015.

The Strategic Technology Programme for Flowline Systems also covers associated subsea structures like Pipeline End Terminations (PLETS) or In-line Tees. Subsea 7 has developed an innovative, modularised design methodology for

Extensive portfolio of high-performance and cost-effective flowline systems to enable optimal field architecture

- Active Heating Systems
- Electrically Heat Traced Flowlines – the most energy efficient system on the market
- Longer tie-backs – development of cold flow technology
- Pipe-in-Pipe with industry-leading thermal performance
- Enabling more cost-effective solutions
- Integration of continuous health monitoring

subsea structures which allows significant cost reductions through a fit-for-purpose approach taking into account design, procurement, manufacture and installation, as well as operations.

This approach is illustrated by the development with BP of a hybrid foundation applied on FLET, and then successfully implemented on Erha North Phase 2 for Exxon. This type of superficial foundation allows an increased load-bearing capacity of the structure onto the soil by adding four pin piles at each corner to resist high lateral buckling loads. This replaces traditional mitigation methods which use anchoring piles and chains.

In parallel, Subsea 7 has developed a suite of in-house design tools using robust design analysis for spools and jumpers. These provide an optimised spool geometry which is less sensitive to certain parameter uncertainties. Combining this with a modularised design approach for the subsea structure provides significant cost saving on the tie-in.

These examples highlight some of the ongoing technology developments within Subsea 7. Through active client engagement and field architecture studies supported by Technology Development Roadmaps and Technology Readiness Level Assessments, we are committed to provide the right technology at the right time and cost to support our clients' field development ambitions. •

From concept to commercialisation:

MARKET-READY ELECTRICALLY HEAT TRACED FLOWLINE

By **Arnaud Reveillox** | EHTF Project Manager

In line with our ongoing commitment to develop effective solutions for technologically-challenging markets, Subsea 7 has successfully commercialised one of the most efficient pipeline heating solutions in the subsea industry: the Electrically Heat Traced Flowline (EHTF).

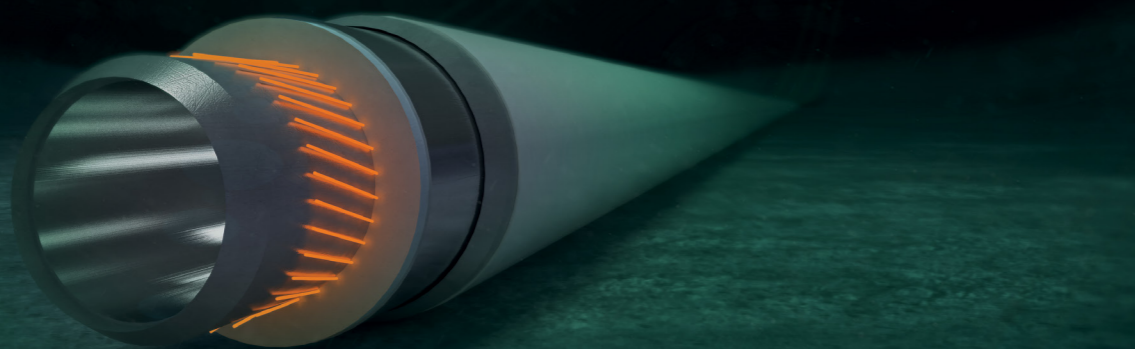

In the current market of low oil prices, new technologies which reduce field development costs are pivotal to enable investments by both operators and contractors. Electrical Heat Traced Flowline (EHTF) Pipe-in-Pipe (PiP) is a positive “game changer” for clients, since this innovative technology has the potential to deliver significant overall cost savings on both CAPEX and OPEX projects.

This potential has been confirmed by the high degree of interest already shown by operators who are considering Subsea 7 EHTF technology for future developments.

EHTF PiP: key differentiators

The EHTF technology is based on high-performance Pipe-in-Pipe (PiP) thermal technology (PiP with Izoflex® insulation within a reduced pressure annulus) combined with multiple triplets of three-phase low-voltage wires, providing a low-power heated pipeline.

The pipeline section is heated by using the Joule effect created by electrical current passing through wire triplets. Flowline heating is powered from the topsides via umbilicals, with a configuration offering a versatile operating philosophy and enhanced redundancy and reliability.

EHTF Pipe-in-Pipe has a significant global potential for transforming field development and operating capabilities by:

- Improving the availability of production systems due to enhanced thermal performance and reheat and hydrate melt-out capabilities
- Simplifying field architectures as an effective technical enabler, permitting long tie-backs with no round-trip, pigging looping requirements from existing brownfield facilities
- Allowing for access to previously inaccessible and demanding reserves through permanent production heating
- Allowing for independent operation of brownfield tie-backs with shut-in capabilities
- Reducing or eliminating the need for chemical flow assurance alternatives

EHTF is currently developed for conventional pipelay by the Reel-lay method.

The EHTF configuration is based on a triplet arrangement, with each one operated from topside or integrated subsea control modules. This provides a more suitable operating solution for our clients compared to other heating systems. Integration of spare or redundant triplets within the cross-sectional array allows for easy switching to a spare circuit in the event of an unanticipated failure of wiring circuits. These features of system modularity and change on demand allow for maintaining full redundancy, reliability and flexibility.

Subsea 7 and ITP, our development partner in the EHTF concept, are collaborating with clients to provide comprehensive engineering support at any stages of a development, from early concept studies to tender delivery.

The mutual benefit of collaborating with clients is instrumental to the supply of a robust and adaptable technology tailored to the effective delivery of a specific project. Sharing our knowledge with OneSubsea and Granherne, partners in our strategic technological Alliances, further extends our EHTF capabilities through the provision of a portfolio of options with full EHTF packaging into an integrated global solution from surface to seabed.

EHTF technology has a multi-disciplinary approach, combining mechanical engineering expertise derived from our core pipeline business and integrating electrical engineering with heating components in the flowline annulus. An EHTF Task Force has been formed to fuse these two disciplines and deliver a mature, fit-for-purpose, commercialised product ready for project use.

Assessment of the technology’s market-readiness is conducted through developmental processes in accordance with the API-RP-17N qualification programme, covering three main areas:

- Mechanical and thermal system; EHTF cross-section integrity checked through full scale tests.

- Electrical system; comprising electrical cables and their in-line connections.
- Temperature monitoring system; achieved by using existing fibre optical technologies.

During 2014-15, a testing campaign was conducted to validate all EHTF sub-components. This included full-scale pipe bending tests, constructability tests by PiP insertion performed at our Wick fabrication base, and extensive electrical testing with short-term and long-term electrical ageing tests as well as fibre optic temperature measurement.

Having achieved a satisfactory level of maturity in our qualification programme, our attention is now fully focused on EHTF commercialisation.

The EHTF team is jointly working with spoolbase operational teams to develop fabrication approaches for the system. Fabrication methods will comply with wide-ranging environmental considerations for all countries of execution as well as with Subsea 7’s own environmental policies.

Consideration is now being given to introducing the technology to existing spoolbases and remote locations to enable new oil and gas province field developments to be brought on stream.

A key element of commercialisation was the development of a cable helix machine, a new production unit which can be integrated within a stalk fabrication fireline to enable the wire triplets to be arranged.

Subsea 7 has invested heavily in this technological development in anticipation of future trends in the subsea market, with heat tracing of the flowline the next step in thermal management.

EHTF is not only a highly cost-effective solution from a CAPEX perspective when compared to other available systems, but, because of EHTF’s world-leading insulation performance, it also minimises power requirements for in-service usage. Our advanced engineering capability provides further ease of use for construction and operational functionality. •



EHTF – TYPICAL CROSS-SECTION:

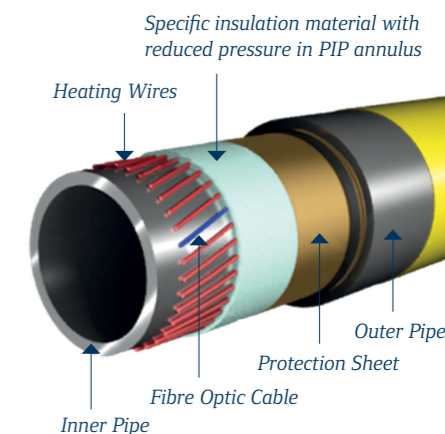



Pipeline Bundles

- The Next Generation

By **Martin Goodlad** | Strategic Technology Manager, Bundles, R & D

Enhancing Bundle technology solutions

To reduce field development costs, we are exploring a number of scenarios including the feasibility of expanding the application of existing Pipeline Bundle technology to new geographical regions and developing new technology to increase the product's applicability.

One key consideration is the length of Bundle that can be towed, which has a profound influence in the applicability of new Bundle fabrication sites.

The investigative programme has confirmed that we could tow considerably longer Bundle systems than we do at present. Analysis has demonstrated that there is no significant increase in fatigue during tow.

The additional length of the Pipeline Bundle system does not impact the ability of the Bundle to operate under High Pressure/High Temperature (HP/HT) conditions, where the axial compressive forces are reduced due to the system expansion. This development also focused on addressing efficient and quick tie-in systems which is the focus of further development work with our alliance partner OneSubsea.

Pipeline Bundles with a nitrogen-filled carrier pipe and adopting high-strength Corrosion Resistant Alloy (CRA) flowline materials and wet insulation materials could be installed in water depths to 900m using

existing carrier technology.

By adding additional nitrogen to the carrier annulus during an offshore pressurisation phase and using the off-bottom tow technique for the final part of the tow route it is possible to install the towed Bundle in depths around 1100m.

Additionally cross-sections have been developed using the open Bundle concept for deepwater. Cost comparisons with conventional pipelay have demonstrated between 12-20% reductions in cost (specific to field development and geographical regions).

Weight is a key driver in deepwater Bundles, so the development programme links strongly with the use of composite components. Subsea 7 is working closely with composite manufacturers to be able to

include composite pipes within the Bundle cross-section.

A major benefit is the reduction in weight which reduces the buoyancy required provided either by the carrier pipe or by solid buoyancy. Inclusion of lightweight composite pipe within the Bundle does not pose the same challenges faced by installing such a lightweight (buoyant) product using traditional pipelay methods.

Pipeline Bundles therefore provide an excellent vehicle for the adoption of composite technology with the fatigue and corrosion-resistant properties that they provide but without the constraints of lack of on-bottom stability.

We are also investigating the use of composites for other components within the Bundle, including an alternative to steel spacers (spacers hold the inner contents in the defined configuration), and the development of composite mud-mats for use on the towheads.

The composite spacer analysis has demonstrated that the overall Bundle cost for specific configurations can reduce as the total required buoyancy is lower.

Composite mud-mats have been successfully trialled using a modified towhead to demonstrate adequate wear resistance during the launch procedure for Bundles.

Extending High Pressure/High Temperature limits to 220°

Pipeline Bundles provide a viable solution for HP/HT fields where alternative pipelay solutions can be uneconomical due in part to the need for global buckling mitigation measures. The HP/HT development aims to increase the operating limits to 220°C, 20kpsi (1379 bar).

Pipeline Bundles are laid on the seabed and are therefore free to expand at either end, which relieves the build-up of axial forces. This removes the need for expansion spools and cooling spools and potentially reduces the flowline wall thickness requirements.

Phase 1 of the development was completed in 2015, with phase 2 full-scale testing due to commence in Q2 2016. The analysis work to date has demonstrated that, through the use of pre-tensioning of the production line against the sleeve pipe (for a Pipe-In-Pipe within a Bundle), the target operating condition of 220°C, 20kpsi (1379 bar) can be met.

The trials programme will involve mechanically tensioning the production pipe utilising a 600te jacking system. The pre-tension will then be locked-in and the 170m test rig will be heated to 220°C and pressurised to prove the system performance at high temperature.

To monitor the pre-tensioning and heating cycles, a full fibre-optic monitoring system has been installed which will measure axial strain and temperature along the full length of the test rig. Hoop strain will be measured in three discrete locations. Analysis of the axial strain which is measured using three independent fibres equi-spaced at 120° will also allow the measurement of bending movement.

The Pipeline Bundle HP/HT development meets the technology development requirements of DNV-RP-C203, and the fibre-optic system provides the empirical measurement to demonstrate that the system performs to expectations computed through finite element analysis. The fibre-optic system will be qualified during the HP/HT trials by inclusion of independent strain gauges that have also been installed on the production and sleeve pipes. This will provide two sets of independent results for comparison.

Internal component development is also required for the realisation of an HP/HT Bundle. Working in collaboration with one of our key suppliers, a low-cost Pipe-In-Pipe (PIP) centraliser has been developed. The centraliser can withstand long-term service at 220°.

This has led to improved performance at approximately 95% lower cost than for the current alternative material and design. •

Enhancing Bundle technology solutions for future markets

- Multiple flowlines packaged inside a carrier pipe
- Terminates with towhead structures (manifolds)
- Fabricated onshore in a single length
- Towed to site by Controlled Depth Tow Method (CDTM)
- Offers integration of subsea processing functions
- Unique cost-efficient solution

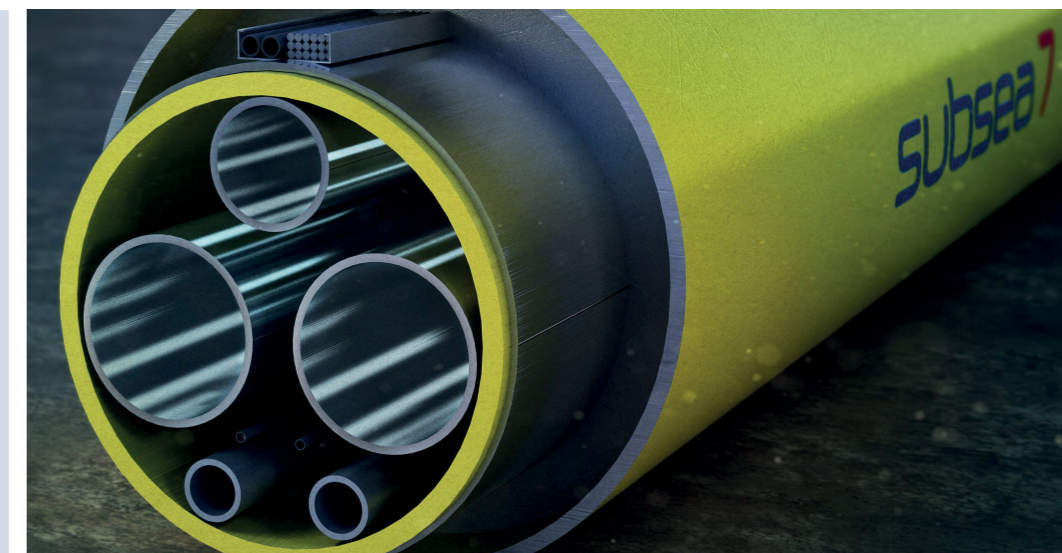

Subsea Processing in Towed Production Systems

The subsea challenge:

Temperature and pressure conditions in export pipelines can cause flow assurance issues like hydrate or wax formation leading to the blockage of flowlines and the subsequent arrest of production. The normal flow assurance mitigation strategy so far has been to maintain temperatures above the hydrate and wax formation temperatures.

As a first stage, this can be done by insulating the flowlines to reduce temperature loss. If the tie-back distance between the subsea field and the host increases, however, the temperature losses are larger, and even more insulation around the flowlines may be required. This can be achieved by high-performance insulation products like Pipe-in-Pipe (PIP).

By **Sigbjørn Daasvatn** | Strategic Technology Development Manager, Subsea Processing

In some cases, active heating by electrical resistance heating or by a circulating a hot flow medium such as heated produced water can be applied to the pipeline system. The changing requirements of different fields have led to the development of various flowline and Pipeline Bundle solutions throughout the years.

Subsea processing

Subsea Processing (SSP) aims to move the entire, or parts, of topside processing facilities to the seabed. SSP can incorporate a number of different processes to help reduce the cost and complexity of developing an offshore field.

Typical subsea processing functions can be two-phase separation of well streams into gas and liquid or three-phase separation into gas, oil and produced water. Produced water may be filtered for sand before re-injection at the bottom of reservoirs, while gas and liquids are boosted to higher transport pressures using wet gas compressors for gas flowlines and pumps for liquid-dominated flowlines heading back to the host platform.

A significant benefit of SSP will often be to simplify the production systems, in turn reducing the need for platform equipment including many of the associated sub-systems. SSP provides the ability to increase recoverable reserves and further enhance the economic viability of projects by optimising production.

SSP technologies address such flow assurance issues as formation of hydrates and wax at source, and they reduce slugging and the need for chemical injection in general.

SSP will in many cases represent enabling technologies for marginal fields, long-distance and deepwater subsea tie-back developments. The uncertainty of deploying new subsea-based processing technology was initially viewed as too great when its potential was first assessed between the 1970s and the 1990s. Today, SSP technology has matured to become one of the dominating technology themes in subsea field developments.

Towed Production Systems (TPSs)

Subsea 7 has produced towed Pipeline Bundles since the early 1980s, and in the late 1990s began further development of the Towed Production System (TPS) to integrate emerging subsea processing functions into enlarged pipeline bundle towheads to suit specific field requirements.

This waned due to the lack of qualified subsea processing equipment at that point in time. Today, by contrast, we have access to all of the key subsea processing functions.

The major benefits of the TPS are reduced installation costs compared with lifting solutions, eliminating the need for specialist installation resources and allowing for onshore prefabrication, with full system quality assurance and control before tow-out.

New field development solutions

Subsea 7 is currently working on integrating existing processing technologies at the most logical locations in various subsea developments, from wellhead to

Subsea processing technology solutions for the global market:

- Integration of subsea processing functions into Towed Production Systems
- Short- or long-distance tie-backs in both shallow and deep waters
- Pre-fabricated onshore at different manufacturers
- Assembled into Submerged Production Units inside dry dock
- Integration of subsea processing functions
- System testing and verification prior to tow operation
- Towed to site by Controlled Depth Tow Method
- Reduced requirements for heavy-lift vessels
- Combined with Bundles when desired
- Unique cost-efficient and low-risk solution which provides new possibilities for field developments as well as enhanced recovery rates

top of risers. Integration work is linked to existing prospects and solutions are currently being proposed to clients. In this way, we aim to develop and offer advanced subsea architecture as a total field development solution.

In order to identify the most economic field development solutions, we believe it is necessary to evaluate the entire process of transporting well streams from the reservoir to the host facility, with increased focus on the reservoir conditions and the fluid flow to the host platform.

We are therefore currently working in close collaboration with our new technology alliance partner OneSubsea to develop integrated subsea solutions which will add real value for our clients. •

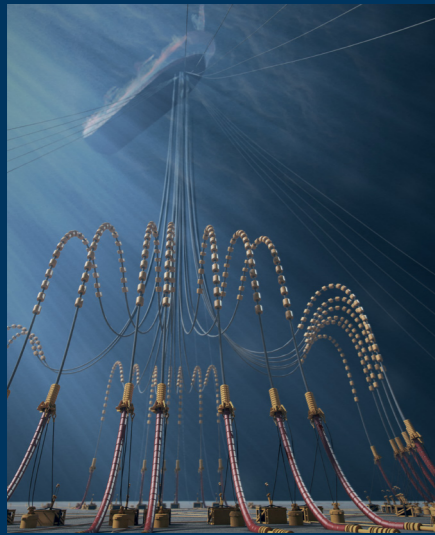

Engaging early to deliver value

The Granherne-Subsea 7 Alliance

More than ever before, operators are seeking novel and reliable concepts to overcome such major industry challenges as complex reservoirs, cost control and growth scope, and to optimise the capital expenditure of subsea projects.

Combining industry-leading design and engineering services, pipeline and riser technologies, and an extensive subsea installation track record, Granherne and Subsea 7 have formed an Alliance that is strategically positioned to collaborate on concept, pre-FEED and FEED engineering for subsea oil and gas developments.

Through earlier engagement at the project definition phase, and by combining the front-end planning capabilities of Granherne with the proven subsea solutions, technologies, and EPCI experience of Subsea 7, the Alliance can identify opportunities to reduce overall field development costs and ultimately deliver economically viable solutions, in line with client requirements.

In the past, the concept selection phase has traditionally been performed by oil companies with the support of an engineering design company. Typically, installation contractors would only become involved with a development post-sanction or at the project tender phase.

This approach resulted in a contract award with limited influence to add further value during the execution phase.

One of the key benefits of early engagement is to realise the value proposition achieved through our Alliance which provides an independent perspective by combining technical experience and integrating new technologies into developments.

The Alliance aims to be a project enabler, lowering costs and streamlining schedules with a combination of theoretical and practical experience.

To demonstrate this potential for a step-change approach, the Granherne/Subsea 7 Alliance recently concluded an innovative pre-FEED study for one of our key clients on a new development planned for offshore UK.

The most viable option for this development required a hot-tap connection into a host pipeline to realise production to a processing facility. Conventional methods such as Welded or Mechanical Tee solutions would typically be investigated at this stage. Through the Alliance, however, we quickly identified an additional technology enabler for investigation in the study, leading to the subsea grouted tee as a proposed alternative solution.

Current hot-tap technology presents issues such as size, weight and the requirement for fine alignment during installation.

These are critical parameters in the design of a system to tap into larger diameter pipelines. Such fundamental issues can also have a detrimental effect on the choice of installation vessels and suitable weather window to perform the installation.

In contrast, a grouted tee option can easily be applied with epoxy technologies to provide greater installation tolerance variations which reduce the risk to existing infrastructure and mitigate overall project risk.

During the pre-FEED phase, three concepts were screened and subsequently evaluated by the Alliance and presented at a client screening workshop. The most cost-effective and technically-compliant solution was selected to move through to the FEED stage.

It was important to minimise CAPEX expenditure without compromising production for our client, and the selected solution delivers significant technical, schedule and cost benefits.

This pre-FEED work demonstrated the benefits of early engagement of the Granherne-Subsea 7 Alliance in introducing enabling technology at an earlier phase in the project.

This example greatly enhanced the project viability evaluation for the client, and we believe our Alliance will deliver similar improvements to other clients around the globe. •

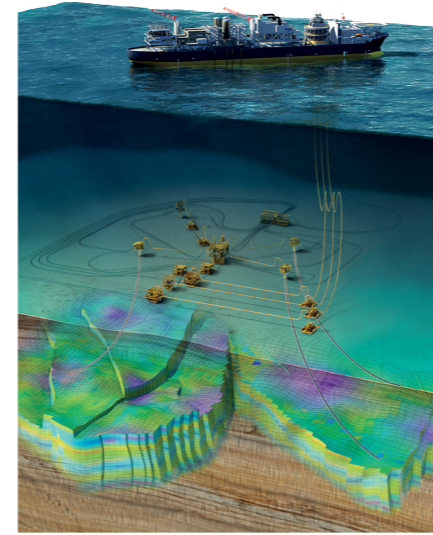

OneSubsea Alliance FOCUS ON TECHNOLOGY

In July 2015, Subsea 7 entered into an Alliance with OneSubsea, a Schlumberger company, to jointly pursue the opportunities that could be developed to provide enhanced solutions to our customers by combining the knowhow and capabilities of SPS (Subsea Production Systems) and SURF.

A key feature of the Alliance is our goal to collaboratively develop innovative products that bring value to our customers and our shareholders. In support of this, we have established a joint R&D budget and have begun to execute our first R&D projects together.

OneSubsea is a market-leading subsea technology company with product lines in production systems (subsea trees, manifolds, controls, wellheads and other related products), processing systems (boosting, compression, separation) and subsea services (aftermarket support, well intervention, condition monitoring and integrity management, surveillance systems).

An important capability within OneSubsea is its Integrated Solutions team which enables seamless optimisation of the entire subsea production system from the reservoir to the surface, including well completions and subsea production systems, by leveraging the combined capabilities of the in-house reservoir

expertise and subsea production and processing technologies.

OneSubsea delivers maximum value to its clients by combining expertise in its Early Engineering, Production Assurance and Petro-Technical Services (reservoir engineering) groups that focus on early engagement with clients and provide a holistic view on the development of optimal production systems.

The technical and technology agenda for the Alliance has been established through a variety of inputs from early pursuits, studies, key stakeholder engagement and workshops. These have provided a rich source of opportunities with ideas that could potentially provide solutions to common interface issues and others that may lead to new products and Intellectual Property (IP).

These opportunities have been segregated into Integrated Technical Collaboration (ITC) and New Technology Development (NTD). The areas within ITC are focused on identified inefficiencies where no new IP is anticipated, although there is value in resolving the underlying issue. The work here is focused on support of winning new contracts and addressing the key issues of cost reduction, risk mitigation and integrated working.

Our NTD agenda concentrates on identifying areas of potential joint product development. An early part of this work is understanding and enhancing the potential

value that could be realised from the synergies of our existing portfolios.

In-depth studies of our complementary technologies are a first step towards effective joint product development, and offer the Alliance the possibility of early technological gains. They also build a common knowledge base which gives our respective experts the creative processes for new product development.

NTD early focus areas

We have a workgroup looking at the integration of subsea processing within a Bundle towhead and in particular at the subsea boosting technology in which OneSubsea specialises. The group will also look at other complementary technologies for new development within the Bundle and processing sector.

A second group is working on long tie-backs. Both companies possess complementary technologies that enable production to be extended beyond current technical limits, and the workgroup is initially focused on EHTF and subsea power, with and without boosting, as well as coldflow, separation and boosting.

Integrated surveillance and intervention is another area where both companies have strong capability and focus, and again the initial development work is focused on realising potential synergies within existing portfolios and new technology possibilities. •

WINTERSHALL MARIA

New thinking in a mature area

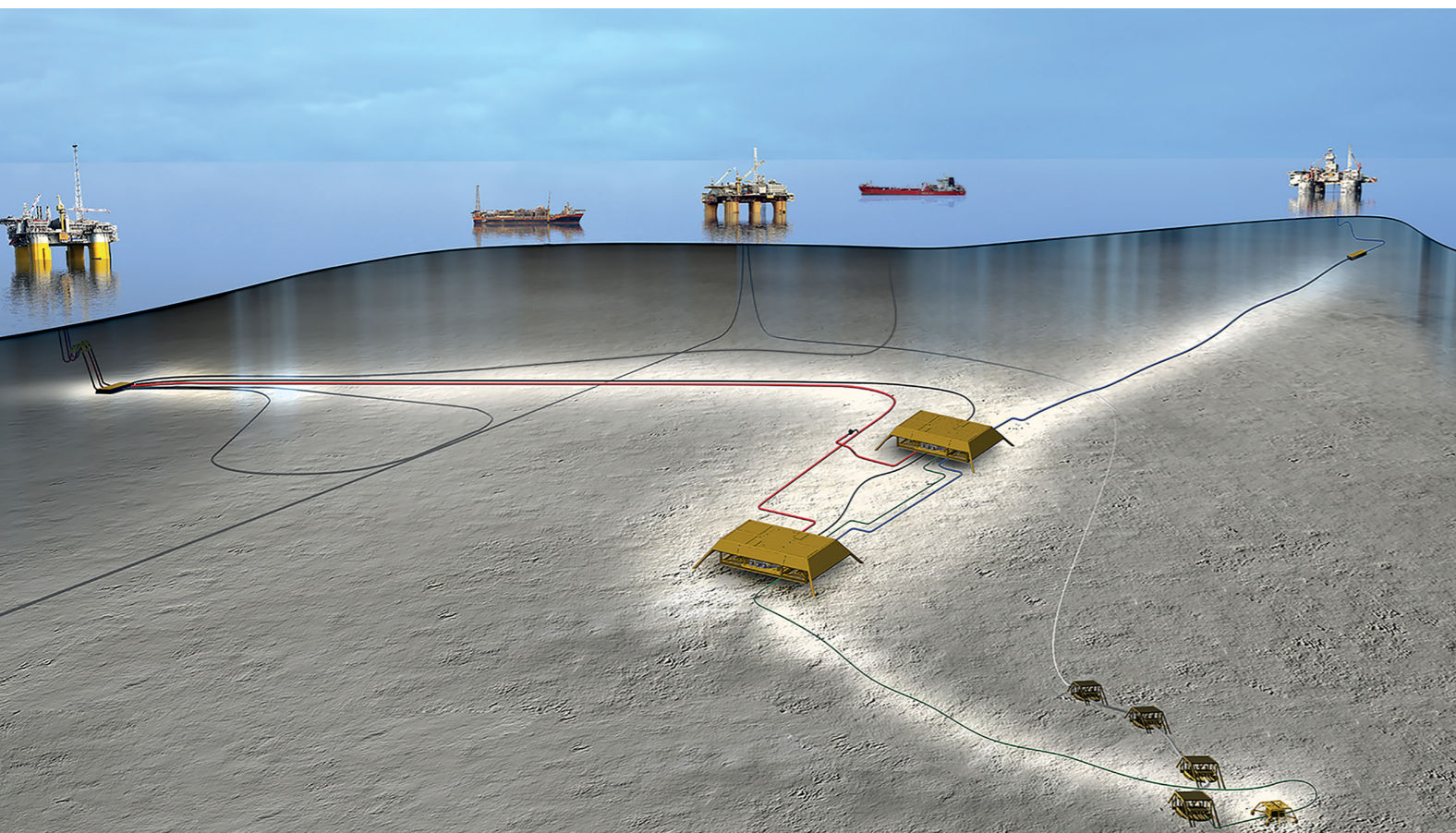

The Maria development is situated in the Haltenbanken region of the Norwegian Sea, a mature area with a range of existing fields and export infrastructure. The development strategy for the project is novel, with the field connected to three hosts in three different fields. The produced fluids are to be exported to the Kristin platform, water for injection is to be supplied from the Heidrun platform, and liftgas will be supplied from the Åsgard field via the Tyrihans D subsea template.

By **Per Moi** | Project Director, **Rasmus Haneferd** | Engineering Manager and **Ove Skorpen** | Engineering Manager

The development required innovative thinking from Subsea 7 and ultimately led to a technology-rich proposal combined with a lean and cost-efficient implementation. As we began collaborating with the Wintershall team, we came to recognise that they had the ambition and

willingness to further challenge existing ways of working and to pursue additional cost savings. The Subsea 7 team has subsequently embraced this opportunity by continuously challenging itself to engage with Wintershall and improve on the base-case solution.

Direct Electrical Heating and with Reeled BuBi® Pipe

The production pipeline for Maria posed a number of challenges originating from the high pressure and temperature of the well stream, the need to accommodate sour

service as well as a requirement for active heating of the pipeline. Subsea 7's solution, developed using our internal design and analysis capability, was to deploy reeled BuBi® pipe with a DEH active heating solution. This will be the first implementation of reeled CRA-lined carbon steel pipe with a DEH active heating system in the world.

We built confidence in this solution by performing qualification work prior to, and in parallel with, the tendering activity and during the first phase of the project. This is a good example of how focused innovation can deliver value for our clients, and how Subsea 7 can be trusted to deploy innovative solutions for first use.

An advantage of deploying BuBi® pipe is that the heat-affected zones at the end of each pipe joint are fabricated using alloy 625. This ensures that the functional requirements for corrosion resistance are achieved, even if the liner is made from a lower grade material, such as alloy 316. This was an important factor during qualification and selection of materials for the Maria project and a major contributor to cost reduction for the development.

Use of BuBi® pipes has proven to be both technically efficient and cost-effective, and the Maria BuBi® pipe is the largest diameter reeled BuBi® pipe to be installed to date by Subsea 7.

Cost-efficient pipeline protection

Trawling protection of subsea pipelines is traditionally achieved with either trenching or by the installation of rock cover over the pipeline. For the Maria project, Wintershall had identified structural reliability analysis (SRA) as a potential opportunity. Subsea 7 developed an approach to use SRA for pipeline free-spans subject to trawl-loading. This work was performed by our engineering teams in collaboration with Wintershall and DNV, with the goal of removing the conservatism necessarily included in a standardised LRFD design approach.

The outcome of deploying this approach has been to demonstrate that stresses



within the pipe free-spans during trawl interaction are acceptable and the pipeline may remain exposed on the seabed, with free-spans of up to 70 metres during the operational life of the pipeline. This approach is being used for both the BuBi® production pipeline with DEH piggyback cable and the polymer-lined water injection pipelines.

The SRA approach ultimately saved the cost of approximately 3-400,000 tonnes of rock for the two pipelines combined. This is another notable 'first', and also an example of how we are able to deliver elegant solutions through the use of advanced engineering approaches deployed by our design teams.

Extended SRA use

For the first time, the SRA approach has also been deployed to remove conservatism in the assessment of spool bend capacity. Adopting the SRA methodology allowed us to take a rational approach to cross-section ovalisation and wall thickness reduction caused by induction bending. Ultimately we are able to increase the utilisation of spool bends, and so enable them to be fabricated from standard line pipe.

Weight reduction

Existing subsea structures in the Maria area are typically large steel structures with suction bucket foundations for stability.

For the Maria project, Subsea 7 has developed a manifold structure concept based on a lightweight gravity-based structure with GRP protection stabilised by rock dump.

This reduces the weight of the structure from 140 to 40 tonnes. This innovative approach considers the steel gravity base, GRP protection and rock dump as a system with a multi-disciplinary team of structural, naval, hydrodynamic and geotechnical engineers working within an integrated team. Subsea 7 previously developed this approach for the Statoil Mariner project, and we have further refined it for the Maria project.

Innovation is the key

We already see the achievement of significant cost savings through a combination of the first use of new products, innovative engineering design methods, a flexible contracting approach and the close collaboration between our in-house and the client's design teams.

The common theme through all of these is an openness to innovate, to challenge orthodoxies and to leverage our organisation to deliver the required outcome for our clients. We have greater ambitions for the future, and aim to make Maria a starting-point rather than an end-point in our 'innovation journey'. •

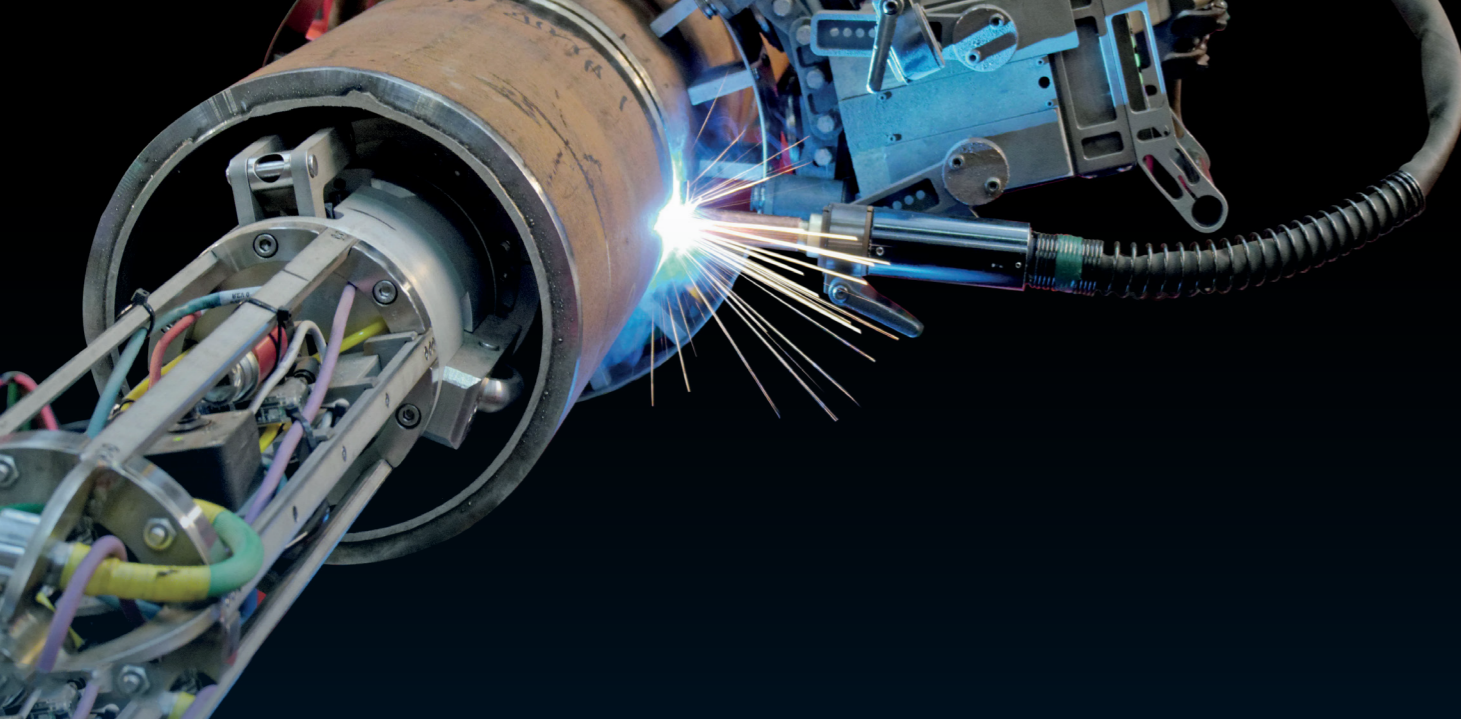

Pipeline Production Team (PPT) LEADING-EDGE WELDING TECHNOLOGY

By **Richard Jones** | Pipeline Production Team, Technology Development Manager

The development and implementation of leading-edge pipeline production technologies continues to be a primary focus for Subsea 7.

Our in-house central technical authority for pipeline welding, NDT and field-joint coating for rigid pipelines is called the Pipeline Production Team (PPT), located in our Global Pipeline Welding Development Centre in Glasgow, UK, with the capability to provide leading-edge welding and inspection solutions for the full range of pipeline fabrication needs.

Heavy Wall Pipe

Steel Catenary Risers (SCRs) are a sustainable solution for the production and export of offshore hydrocarbons in many deepwater developments. In the Gulf of Mexico (GOM), the development of High Pressure/High Temperature (HP/HT) wells

drives the design of risers to incorporate heavy wall pipe thickness.

Typical riser wall thickness may be up to 36mm for 8"-10" OD pipelines, with even greater wall thickness projected in the future. For the fatigue-loaded sections of such risers, very stringent weld flaw acceptance criteria apply. This presents a significant production challenge if the use of cost-effective welding solutions is to be maintained. Welding of such thick-wall pipe to high-quality requirements is challenging if repairs are to be minimised.

A key success factor in the GOM is our ability to demonstrate a capability to meet critical SCR weld-quality criteria on a repeat basis. The PPT recognised that this required a step-change in Pulsed Gas Metal Arc Welding (PGMAW) technology.

PPT embarked on a development programme to qualify a welding solution to satisfy the requirements for critical

SCRs, the basis of which was the use of the Cold Metal Transfer (CMT)/PGMAW process. Critical steps towards achievement of this goal included the following welding technology improvements:

- Use of a very narrow bevel configuration to reduce the weld width at the pipe OD
- Development of an advanced PGMAW synergic waveform using optimised Ar-CO₂ shielding gas to give improved arc stability and weld metal transfer.

PPT worked with CRC-Evans and Fronius to develop an advanced PGMAW wave form. High-speed video was used together with high frequency data acquisition techniques to monitor the arc and metal transfer behaviour. This confirmed that the existing PGMAW waveform was characterised by occasional arc instabilities giving non-uniform droplet melting and non-axial metal transfer resulting in an agitated weld pool. These conditions were believed to increase susceptibility to lack of fusion flaws.

Instabilities were eliminated through waveform optimisation so that welding conditions giving stable metal transfer together with acquiescent weld pools could be continuously maintained. This further understanding of the arc and its variable effects allowed for the production of welds in heavy-wall pipe which meet and exceed the quality targets.

This approach helped PPT and CRC-Evans welding engineers to optimise the PGMAW waveform with a consequent significant improvement in weld quality. The first deployment of this welding solution for heavy-wall SCR was for the Statoil Aasta Hansteen project, with the production of a 14" x 28.6mm gas export line in 2015 in our Vigra spoolbase in Norway.

Welding production rates and weld quality greatly exceeded target requirements with an actual reject rate of 0.48% relative to the target. The advanced PGMAW synergic waveform is now being deployed for the fabrication of heavy-wall pipelines in the GOM with similar success.

Welding of clad and lined pipe

Prior to the start of the Aasta Hansteen project, PPT performed a comprehensive review of historical SCR and clad/lined pipe fabrication projects with the aim of capturing all relevant lessons learned. A key difference recognised by Subsea 7 was the increased wall thickness in both clad and CS pipe relative to previous project experience.

Taking this experience into account, PPT identified two areas for technology development in order to ensure a successful fabrication campaign for Aasta Hansteen:

- Improved CMT/PGMAW performance for both CS and clad/lined pipe in heavy-wall pipe
- Capability for performing full pipe body demagnetisation in the spoolbase.

The following technical improvements were then achieved in CMT/PGMAW welding for clad/lined pipe:

- Use of an improved CMT waveform in combination with an optimised Ar-He-CO₂ shielding gas composition. This resulted in better process stability and, in combination with the use of tighter root bevel tolerances, gave fewer propensities to burn through flaws.
- The bevel angle was reduced from a prior 10° to 5° so that welds in the heavier wall thickness could be completed with single weave weld passes. Welding parameters

were optimised to ensure that there was no increased risk of lack of fusion flaws. The shielding gas composition used for the PGMAW fill and cap passes, He-Ar-CO₂, was optimised to include the minimum oxidising potential necessary to maintain arc stability while avoiding excessive oxidation of the weld metal.

In order to minimise the risk of recurrence of a residual magnetism problem on such a scale as was experienced during the Sapinhoá and Lula NE fabrication campaign, Subsea 7 decided to establish a full pipe body demagnetisation facility at the spoolbase.

Following a survey of candidate vendors, Vallon, based in Germany, was selected as the preferred supplier. The demagnetisation equipment comprised coils of electrical cable, supported within a rectangular frame and powered by a low-frequency generator. Demagnetisation is achieved by passing the full pipe length through the activated coils and applying low-frequency alternating current (AC) so that the field intensity is progressively decreased until residual magnetism is completely eliminated from the full pipe length.

The demagnetisation equipment was initially set up in Subsea 7's Global Welding Development Centre (GWDC) in Glasgow, Scotland, in order to establish optimum demagnetisation procedures and safe working practices for a range of pipe sizes, types, coated and uncoated. Standard mains frequency is suitable for thin pipe whereas thicker pipe benefits from the use of lower frequency. Safe working distances were determined to eliminate any possible harmful effects of electromagnetic field emissions.

Following demagnetisation procedure trials in the GWDC, the equipment was despatched to and commissioned in the Vigra spoolbase. The equipment was installed within the existing pipe conveyor system so that linepipe, fully free of residual magnetism, could be delivered to the firing line without affecting its efficient movement through the spoolbase.

The Aasta Hansteen fabrication campaign in 2015, comprising both clad and lined pipe, was the first project to utilise this facility, which is now fully transportable to allow deployment in other spoolbases as needed.

The use of full pipe body demagnetisation is considered to be a world first in our



Advanced pipeline welding technologies which include a diverse range of line pipe materials, pipeline fabrication codes and operator specifications

- A Global Pipeline Welding Development Centre
- Corrosion-Resistant Alloy (CRA), high-strength steel materials
- Automated Ultrasonic Testing (AUT) system developments
- Enhanced Field Joint Coating Systems

industry, contributing to higher quality welding with reduced risk of repairs.

Small-Diameter Internal Line-Up Clamp (ILUC)

For small-diameter pipe, typically less than 6" OD, the performance of mechanised welding has been hindered by the lack of an available ILUC. For this reason such pipe sizes have traditionally been fabricated using manual welding processes with consequent limitations on welding productivity and weld quality.

The declining global pool of skilled manual welders also drives the need to establish an enhanced mechanised welding capability. This has now been achieved by PPT using an in-house designed and patented solution. The equipment is designed around 4.5" OD pipe with a capability of working with both carbon steel and CRA/clad pipe.

An ILUC device, including a Cu shoe, has been developed and tested and is now production-ready equipment for deployment on the welding qualification programme for BP's West Nile Delta Project.

The ILUC will be deployed on the fabrication of the 4.5" OD pipeline which will permit the use of mechanised PGMAW welding. It is estimated that the enhanced welding productivity achievable with mechanised welding relative to manual welding will give a five-day reduction in the offshore installation campaign. •

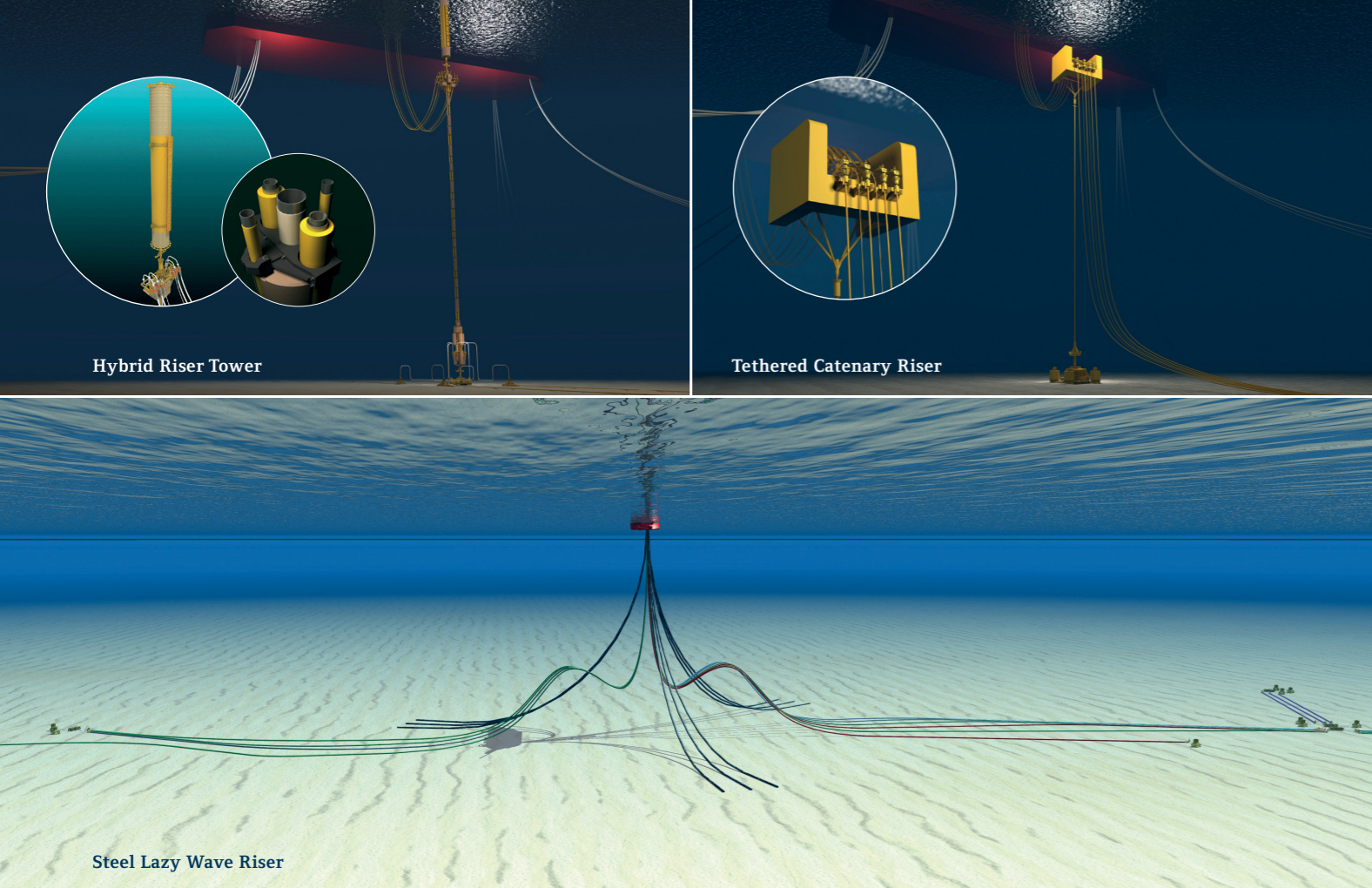

DEEPWATER RISER SYSTEMS: a strong portfolio under continuous development

Riser selection is a key consideration in the architecture of a deepwater project. Over the years, Subsea 7 has developed a unique portfolio of riser systems, representing the widest variety of solutions in the industry and allowing cost-effective selection for each project.

By **Blaise Seguin** | Strategic Technology Manager for Risers & **Yann Brouard** | Risers Lead Engineer

Our role is to maintain our industry leadership in riser systems through the continuous development of our existing solutions and with the addition of new riser concepts.

Recent developments of note are our new Tethered Catenary Riser (TCR), enhancements to our existing proven systems and the development of new riser engineering tools and components.

Riser portfolio

Subsea 7's riser portfolio includes proven decoupled riser systems, such as the Single Hybrid Riser (SHR), the Hybrid Riser Tower (HRT) and the Buoyancy-Supported Riser (BSR). These systems have been successfully applied to major recent deepwater projects: CLOV in Angola (with two HRTs and one SHR) and Guarã-Lula NE in Brazil (with four BSRs). Further proven coupled riser systems include Flexibles,

Steel Catenary Risers (SCRs), both applied on numerous fields, and Steel Lazy-Wave Risers (SLWR), with the first installed SLWR system deployed on the BC-10 project in Brazil.

Having access to a large suite of riser solutions enables us to support clients in selecting the most suitable option for each project, taking into account such field characteristics as water depth, environmental conditions, production

Market-leading portfolio of riser systems

- Cost-effective solutions
- Unique extensive portfolio of riser solutions
- Strong track record, including large EPCI projects
- Optimised riser integration into field development
- Improved flow and integrity performance

floater type, production fluid composition, and other considerations.

Each riser system features a unique combination of capacities and benefits which are screened against the project characteristics during the selection process. Our Tethered Catenary Riser (TCR), developed over the last five years, offers clients a promising new combination of benefits.

Tethered Catenary Riser

The Tethered Catenary Riser (TCR) concept consists of a number of Steel Catenary Risers supported by a subsurface buoy which is tethered to the seabed by a single pipe tendon connected to a suction pile.

Flexible jumpers are used to make the connection between the floating production unit and the buoy. This concept features the following key advantages:

- It is possible to access all risers individually, allowing riser replacement if needed.
- The system can be preinstalled prior to FPSO arrival, reducing the back-end schedule to first oil.
- The deployment and fabrication of the system does not require a fabrication yard located near the field.
- The TCR system is the most cost-effective decoupled riser system, with a saving of 20% to 30% compared to conventional SHRs.

Our most recent development work has focused on the installation of the buoy, the design of which has been engineered so

that the installation method is very similar to the one commonly used by Subsea 7 for SHRs and HRTs. Additionally, buoyancy modules are distributed along the tendon to render it self-standing and simplifying the connection of the buoy, similar to the method of installation we employ for HRTs.

All the components and installation methods utilised in the deployment of the TCR are already field-proven and commonly used in our existing riser systems.

Steel Lazy Wave Riser optimisation tool

The configuration of a Steel Lazy-Wave Riser (SLWR) depends upon a number of parameters; specifically the fatigue resistance of the riser pipe, the payload on the floating production unit and the global cost of the system.

Our team has developed a numerical tool based on the Design Of Experiment (DOE) principle. This performs an automated screening of a large number of SLWR configurations and automatically computes acceptable solutions which meet the design and installation technical criteria. Finally, it selects the optimised configuration in terms of system global cost, integrating the DOE software Isight with the riser analysis software OrcaFlex.

The main benefits of this optimisation tool are: convenient interfaces with the floater reducing the engineering across the system boundaries, shorter design engineering (engineering man-hours are reduced by a factor of two to three compared to standard methods) and the reduction of system global cost by typically around 10% through the reduction in the number of buoyancy modules required, the length of clad pipe and pipe wall thickness.

Enhancement of Hybrid Riser Tower

After three years of design and testing, we have completed the development of the Plastic Stopper, a significant new riser component. This is a polymer structural anchoring point which is over-moulded onto coated pipe.

This new component is of particular interest for Hybrid Riser Tower bundles, as it allows the attachment of buoyancy modules onto an individual riser. This is required for heavy risers such as Pipe-in-Pipes in order to avoid excessive bending moments in the bundle during the upending phase of the HRT installation. Plastic Stoppers can also be used to secure buoyancy modules onto the central core pipe of the HRT bundle, providing a more cost-effective alternative to conventional forged pieces.

The development of the Plastic Stopper required an in-depth knowledge of the behaviour of polypropylene. A number of challenges were presented; the injection of material in such thicknesses, and an understanding of the material's performance when submitted to environmental and mechanical loads during the project life. Particular attention has been paid to creep behaviour (material deformation over time when submitted to continuous loading) under temperature and pressure.

Prototypes have been fabricated for testing under service conditions combining hydrostatic pressure, temperature and mechanical load in a hyperbaric pressure vessel, with parameters selected to account for ageing.

The Plastic Stopper successfully passed the qualification tests and is now validated for application on projects. •

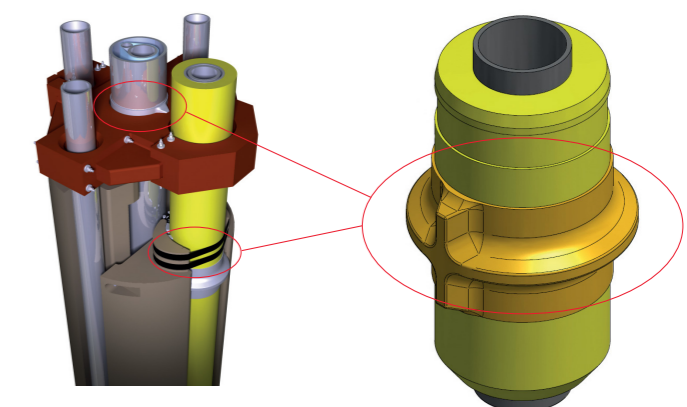

Plastic Stopper: model and integration into an HRT bundle.

COMPOSITES: FROM CONCEPT TO APPLICATION

By **Michael Firmian** | Composite Materials Technology Manager

Subsea 7 is constantly investigating alternative methods and materials for more effective subsea applications. Composites are already widely used by Subsea 7 in some specific applications, such as GRP covers in the North Sea, which have proven to be very successful and where Subsea 7 has built a market-leading knowhow and track record.

At the same time, continuous development is happening in the background to widen the range of our offering and include the use of composites where applicable.

Subsea 7 is engaged in a Joint Development Agreement (JDA), which includes Magma Global, BP and the NCC (UK National Composite Centre) to develop and qualify a product called 'm-Jumper'. This is a subsea jumper made primarily of 'm-pipe', a carbon fibre and PEEK (poly-ether-ether-ketone) pipe for permanent subsea application in the oil and gas industry.

'm-pipe' is a new and unique system being developed for subsea use by Magma Global. The product will undergo a two-year qualification process during which various extreme and operational limitations will be established in order to validate and certify the product for widespread market acceptance and infield application.

This qualification process requires official testing phases to be carried out on the m-Jumper product, in order for it to achieve suitable market readiness. The inspection and monitoring test phases form part of the Subsea 7 work scope, along with the development of an installation procedure.

The inspection of these composite pipes, both for manufacturing quality assurance and for in-service damage detection, has prompted the requirement for further development and adaptation of a number of new and existing methods and techniques.

The unique mechanical properties of the product require our understanding and expertise in order to anticipate its in-place behaviour, as well as the development of a tailored and new installation methodology.

Composite pipes are now making their way into the SURF market and Subsea 7 is in the front line of that technological move.

Through continuous engagement with the supply network, Subsea 7 maintains technological leadership by the introduction of new products and services that bring value to our customers.

Composite materials have enjoyed widespread usage in other industries, such as automotive and aerospace, and the oil and gas sector is now able to take advantage of these developments and capitalise upon them.

Composite materials will be an effective enabling technology to unlock deepwater reserves due to their uniquely high strength-to-weight ratio which limits the need for ever-higher top-tension capabilities on installation vessels.

Composites additionally offer potential solutions to two significant technological challenges for subsea applications - good fatigue performance and corrosion resistance. •



GRP cover design and test lift.

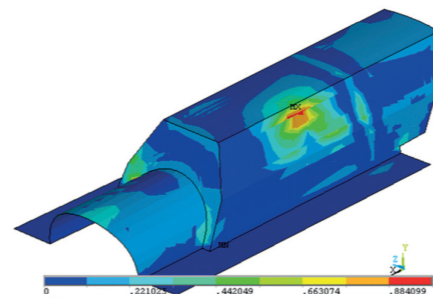

Magma 'm-pipe' product applied on jumper design.



DATA AS THE CORNERSTONE of Life of Field technology strategy

By **Hugh Ferguson** | Strategic Technology Manager, Life of Field

Subsea 7 is developing an integrated suite of technologies which will deliver value to clients across the entire field life-cycle. There is one common and critical component that underpins both our emerging and existing technologies: the need to provide high-quality data.

High-quality data analyses enable informed decision-making to maximise production, optimise condition monitoring and reduce maintenance costs.

Subsea 7 is optimising how that data is captured, processed, transferred, analysed and ultimately made accessible to our clients, through improved access to the data itself as well as the reports and recommendations which form part of our service.

We also enhance the meaningful information through including the knowledge derived from multiple operator experiences.

There are a number of key components to our new approach to Life of Field (LOF) data.

Data architecture and management

This is the key enabling component. The data picture is built up from large numbers of dynamic sensors, surveillance campaigns and inbuilt monitoring systems, all of which are key strategic technologies for Subsea 7.

Those systems, together with client in-house reporting and data management systems, can be unique, proprietary and, when required, locked-in.

We are developing an architecture base that allows the progressive layering and accessing of such varied inputs, while allowing us to optimise our data workflows. This also allows for outputs as specified for clients' proprietary systems and requirements.

Dynamic data acquisition platforms such as the AIV, operate through acoustic and visual sensors, data mining and environmental monitoring, with the added cost efficiencies of autonomous operation. These systems are designed with the data-to-client flow as a primary attribute, not a secondary consideration.

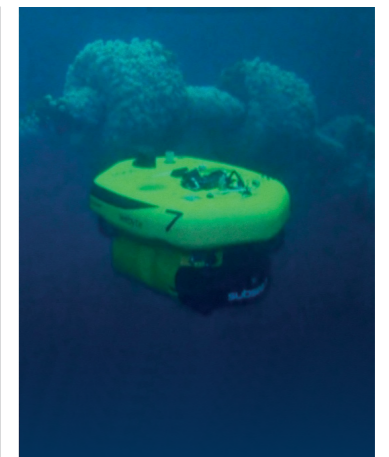

The benefits:

- Secure and managed field data
- Eliminated risk of lost or corrupt data offshore
- Optimised data flow and processing
- Automated anomaly eventing
- Reduced data volumes

All of this ultimately leads to reduced provision costs and maximised value for clients by allowing them easy access to critical information from a large mass of inter-connected digital data. •

subsea 7

deep7 2016

client.enquiry@subsea7.com

www.subsea7.com